

**Interoperability test scenario
for "IPv6 Ready Logo"
Phase-1**

Ver. 1.3.3

IPv6 Forum
IPv6 Logo Committee
February 5th 2007

This documentation describes IPv6 Interoperability test scenarios to obtain IPv6 Ready Logo Phase-1. These scenarios covers the functionalities which is described in common specifications for IPv6 Ready Logo Phase-1.

We categorize some kinds of devices, which is designed for special purpose, as "Special Device". If your device is a Special Device, please follow the test scenario as a Host. And please read the "**Condition**" part in each scenario carefully.

For Host device, you have to run following section.

1. Host vs. Host
2. Host vs. Router

For Router device, you have to run following section.

2. Host vs. Router
3. Router vs. Router

For **Special device**, you have to run following section as a **Host**.

1. Host vs. Host
2. Host vs. Router

We suppose to use these scenarios in "Interoperability test event" and in "Test Laboratories".

Your device has to pass all of these tests to obtain IPv6 Ready Logo Phase-1.

This documentation is discussed and defined in IPv6 Logo Committee.

If you have some comments or recommendations, please send e-mail to IPv6ready-info@ipv6ready.org.

If you are planning to send application for IPv6 Ready Logo Phase-1, please read Chapter " 0. Required data for IPv6 Ready Logo Phase-1" carefully.

--- TOC ---

0. Required Data for IPv6 Ready Logo Phase-1	4
0.1. Required data	5
0.2. Data file name syntax	7
0.3. Data Archive	10
0.4. Application	10
1. Host vs. Host	11
1.1. Ping to Onlink Host with Link-local Address	11
1.2. Ping to Onlink Host with Global Address	13
2. Host vs. Router	15
2.1. Ping between Host and Router – Link-local Address	15
2.2. Ping between Host and Router – Global Address	18
2.3. Ping to Offlink Host	21
3. Router vs. Router	23
3.1. Ping to Onlink Router with Link-local Address	23
3.2. Ping to Onlink Router with Global Address	25
4. Change Log	27

0. Required Data for IPv6 Ready Logo Phase-1

To obtain the IPv6 Ready Logo Phase-1, you need to send application with the test results attached. The test results must include both Protocol Operations and Interoperability. In this document, the "**Interoperability test**" result documentation is described.

There are currently two viable alternatives to obtaining an interoperability result.

- Lab Test: Test results observed at a lab that is recognized by the IPv6 Ready Logo Committee.
- Self Test: Test results observed by the applicant company in their laboratory.

0.1. Required data

As "IPv6 Ready Logo Phase-1" the following interoperability test result data are required.

A) Topology map

Network topology figures or address list for each topology, with IPv6 addresses and MAC address of each attached interfaces, are required. Fig. 0.1 is an example of topology figure. All IP addresses which are used during the test must be declared.

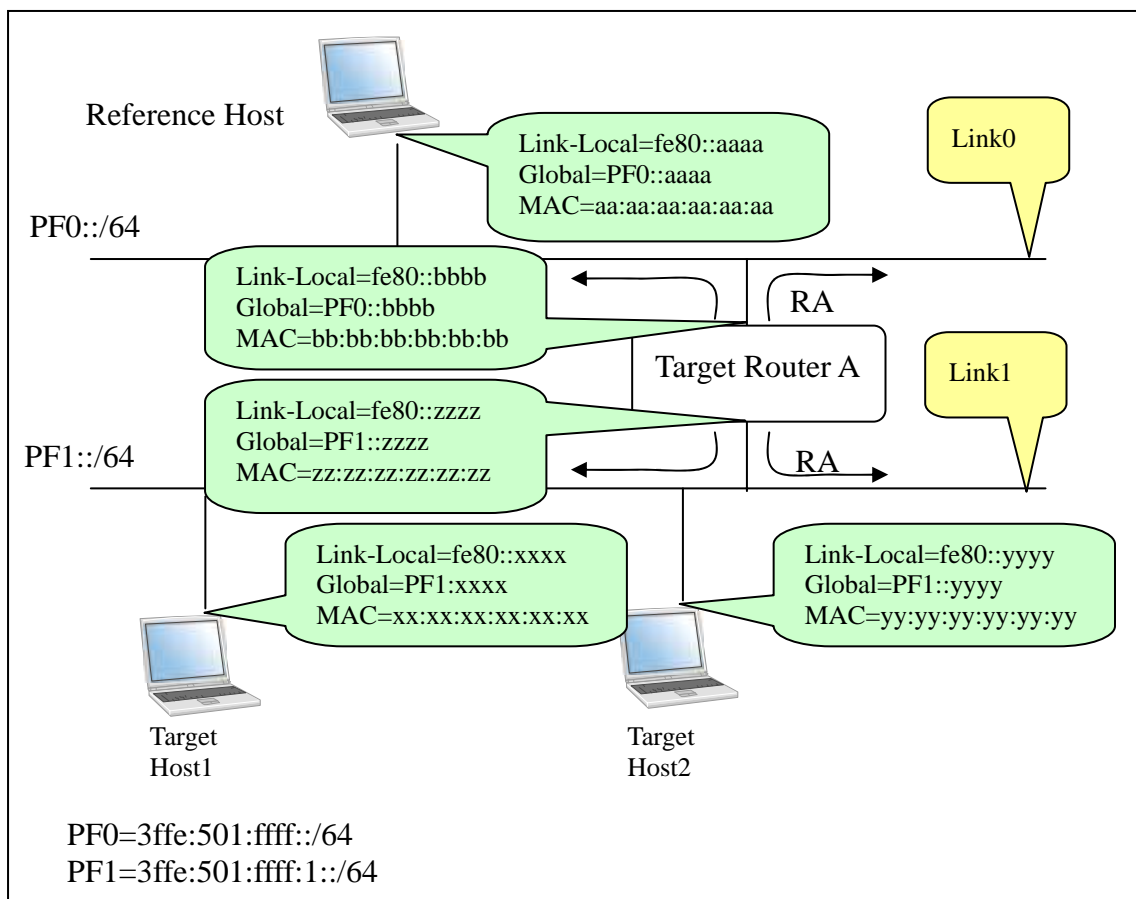

Fig. 0.1 Topology map example

Target Host1:

Link-Local=fe80::xxxx

Global=PF1::xxxx

MAC=xx:xx:xx:xx:xx:xx

Target Host2:

Link-Local=fe80::yyyy

Global=PF1::yyyy

MAC=yy:yy:yy:yy:yy:yy

Target Router A [Link0]:

Link-Local=fe80::bbbb

Global=PF0::bbbb

MAC=bb:bb:bb:bb:bb:bb

Target Router A [Link1]:

Link-Local=fe80::zzzz

Global=PF1::zzzz

MAC=zz:zz:zz:zz:zz:zz

Reference Host:

Link-Local=fe80::aaaa

Global=PF0::aaaa

MAC=aa:aa:aa:aa:aa:aa

Fig. 0.2 Address List example

B) Command Log

Save the command files for each test on each node.

C) Packet Capture File

Capture all packets on each link during the test with a device that is not part of the test.

For each part of test put the captured packet into individual files within tcpdump(pcap) format, or readable HTML format.

If you run tcpdump, please specify packet size as 4096.

e.g.,) `tcpdump -i if0 -s 4096 -w 1.1.Link1.dump`

D) Test result table

Collect all test result tables in a file and fill the tables as required. This file must contain a table where all passes are clearly marked.

0.2. Data file name syntax

Please use following syntax when name your files.

A) Topology Map

For test 1.1-1.2) Syntax:*Chapter.topology*

It should be always **1.topology**.

For test 2.1-2.3) Syntax:*Chapter.Router_Model.topology*

For "Router_Model", use the Router's vendor name which behaved as a target router.

e.g.,)

Test topology from "2.1. Ping between Host and Router" to "2.3 Ping to Offlink Host" with following router.

Router [vendor: VendorB, model: rRouter, version: 2.0]

2.VendorB.topology

For test 3.1-3.2) Syntax:*Chapter.topology*

It should be always **3.topology**.

B) Command Results

For test 1.1-1.2) Syntax:*Chapter.Section.Host_Model.result*

For "*Host_Model*", use the vendor name on which the commands were run.

e.g.,)

Test result for "1.1. Ping to Onlink Host with Link-local Address".

Host [vendor: VendorA, model: rHost, version: 1.2]

1.1.VendorA.result

For test 2.1-2.3)

Operation on Host)

Syntax:*Chapter.Section.Host_Model.Router_Model.result*

Operation on Router)

Syntax:*Chapter.Section.Router_Model.Host_Model.result*

For "*Host_Model*", use the vendor name on which the commands were run.

For "*Router_Model*", use the Router's vendor name, which behaved as a target router.

e.g.,)

Test result for "2.1. Ping between Host and Router" which is operated on Host.

Host [vendor: VendorA, model: rHost, version: 1.2]

Router [vendor: VendorB, model: rRouter, version: 2.0]

2.1.VendorA.VendorB.result

For test 3.1-3.2) Syntax:*Chapter.Section.Router_Model.result*

For "*Router_Model*", use the vendor name on which the commands were run.

e.g.,)

Test result for "3.1. Ping to Onlink Router with Link-local Address".

Router [vendor: VendorB, model: rRouter, version: 2.0]

3.1.VendorB.result

C) Captured packet file

For test 1.1-1.2) Syntax: *Chapter.Link.dump*

For "*Link*", use the captured link name.

e.g.,)

Test result for "1.1. Ping to Onlink Host with Link-local Address".

Link [captured link: Link1]

1.1.Link1.dump

For test 2.1-2.3) Syntax: *Chapter.Section.Router_Model.Link.dump*

For "*Router_Model*", use the Router's vendor name which behaved as the target router.

For "*Link*", use the captured link name.

e.g.,)

Test result for "2.1. Ping between Host and Router".

Router [vendor: VendorB, model: rRouter, version: 2.0]

Link [captured link: Link1]

2.1.VendorB.Link1.dump

For test 3.1-3.2) Syntax: *Chapter.Section.Link.dump*

For "*Link*", use the captured link name.

e.g.,)

Test result for "3.1. Ping to Onlink Router with Link-local Address".

Link [captured link: Link1]

3.1.Link1.dump

D) Test result table

Syntax: *Vendor_name.table*

e.g.,)

Test result of following host.

Host [vendor: VendorA, model: rHost, version: 1.2]

VendorA.table

0.3. Data Archive

Please organize your data as following directory structure.

```
$Your_Device_ver/  
  Self_Test_x-x-x/  
  Interoperability /
```

Put all interoperability data file in "Interoperability" directory.

Make a tar.gz format archive file, and put files under "\$Your_Device_ver" in it.

0.4. Application

In this document, we often use "ping" as an application to send ICMP echo request.

If the target device does not have "ping" application, it is possible to use other application that behaves like "ping" application.

1. Host vs. Host

The test scenarios described in this section are focusing on the interoperability between Hosts.

The **Special Device** also have to perform this test scenario as a **Host**.

1.1. Ping to Onlink Host with Link-local Address

Ping from **Target Hosts** to **Other Target Hosts** using **Link-local Address**.

Evaluation Point:

- ◆ Link-local Address resolution
- ◆ ICMP Echo Request/Reply using Link-local address

Topology:

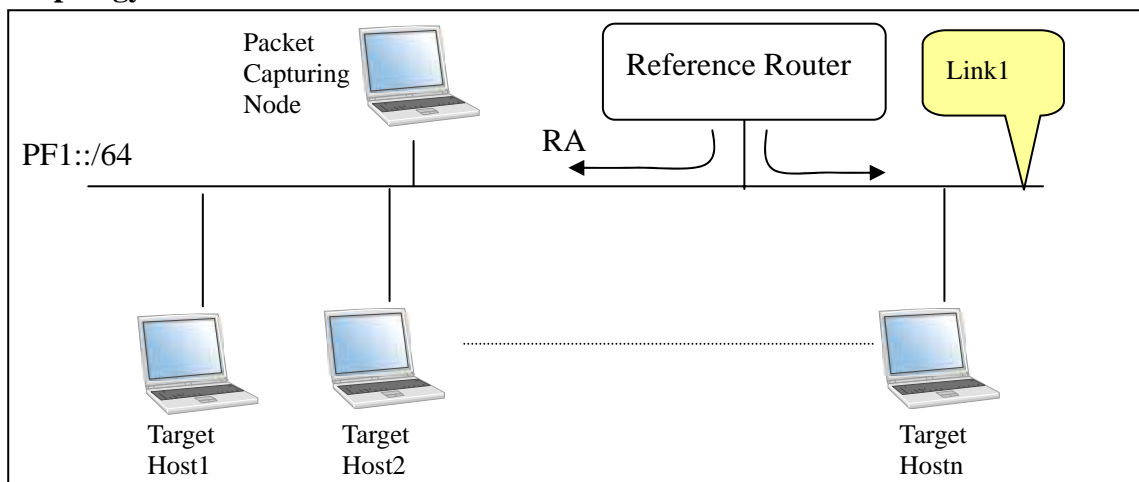

Fig. 1.1 Topology for Host vs. Host

Each Target Host attached to Link1 performs following scenarios.

Condition:

- ◆ If a Host can't send ICMP Echo Request, the node can omit it. But every host has to respond ICMP Echo Reply to received ICMP Echo Request. So all hosts can NOT omit being sent ICMP Echo Request.
- ◆ Reference Router sends RA on Link1
- ◆ If your device is a **Special Device**, and it can not configure the address automatically, you need to assign address on the attached interface manually.
- ◆ If your device is a **Special Device**, and it can not set the default router automatically, set the Reference Router's address as default router manually.

Operation on Host:

Run **ping** on Host listed as "From" to each Host listed as "To".

NOTE: You need to run ping command on your device as well as on other devices to your device.

Save ping command log on each Host to individual file.

NOTE: To examine test result, command log file of every nodes are required.

From \ To	Host1 (Link-local)	Host2 (Link-local)	Hostn (Link-local)
Host1				
Host2				
:				
Hostn				

NOTE: You need to fill all of the cells your device is related.

E.g.,) If your device is Host1, you need to fill both of Host1 Line and Host1 Column.

Operation on Packet Capturing Node:

Capture all the packets of Link1 during the test, and save to a file with tcpdump(pcap) format.

1.2. Ping to Onlink Host with Global Address

Ping from **Target Hosts** to **Other Target Hosts** using **Global Address**.

Evaluation Point:

- ◆ Global Address resolution
- ◆ ICMP Echo Request/Reply using Global address

Topology:

See topology described in Section 1.1.

Condition:

- ◆ If a Host can't send ICMP Echo Request, the node can omit it. But every host has to respond ICMP Echo Reply to received ICMP Echo Request. So all hosts can NOT omit being sent ICMP Echo Request.
- ◆ Reference Router sends RA on Link1
- ◆ If your device is a **Special Device**, and it can not configure the address automatically, you need to assign address on the attached interface manually.
- ◆ If your device is a **Special Device**, and it can not set the default router automatically, set the Reference Router's address as default router manually.

Operation on Host:

Run **ping** on each Host listed as "Host" to Hosts listed as "To".

NOTE: You need to run ping command on your device as well as on other devices to your device.

Save ping command log on each Host to individual file.

NOTE: To examine test result, command log file of every nodes are required.

From \ To	Host1 (Global)	Host2 (Global)	Hostn (Global)
Host1				
Host2				
:				
Hostn				

NOTE: You need to fill all of the cells your device is related.

Operation on Packet Capturing Node:

Capture all the packets of Link1 during the test, and save to a file with tcpdump(pcap) format.

2. Host vs. Router

The test scenarios described in this section are focusing on the interoperability between Host and Router.

The **Special Device** also have to perform this test scenario as a **Host**.

2.1. Ping between Host and Router – Link-local Address

Ping from **Target Hosts** to **Target Routers** using **Link-local Address**.

Evaluation Point:

- ◆ ICMP Echo Request/Reply using Link-local address
- ◆ Link-local Address Resolution (Both side)

Topology:

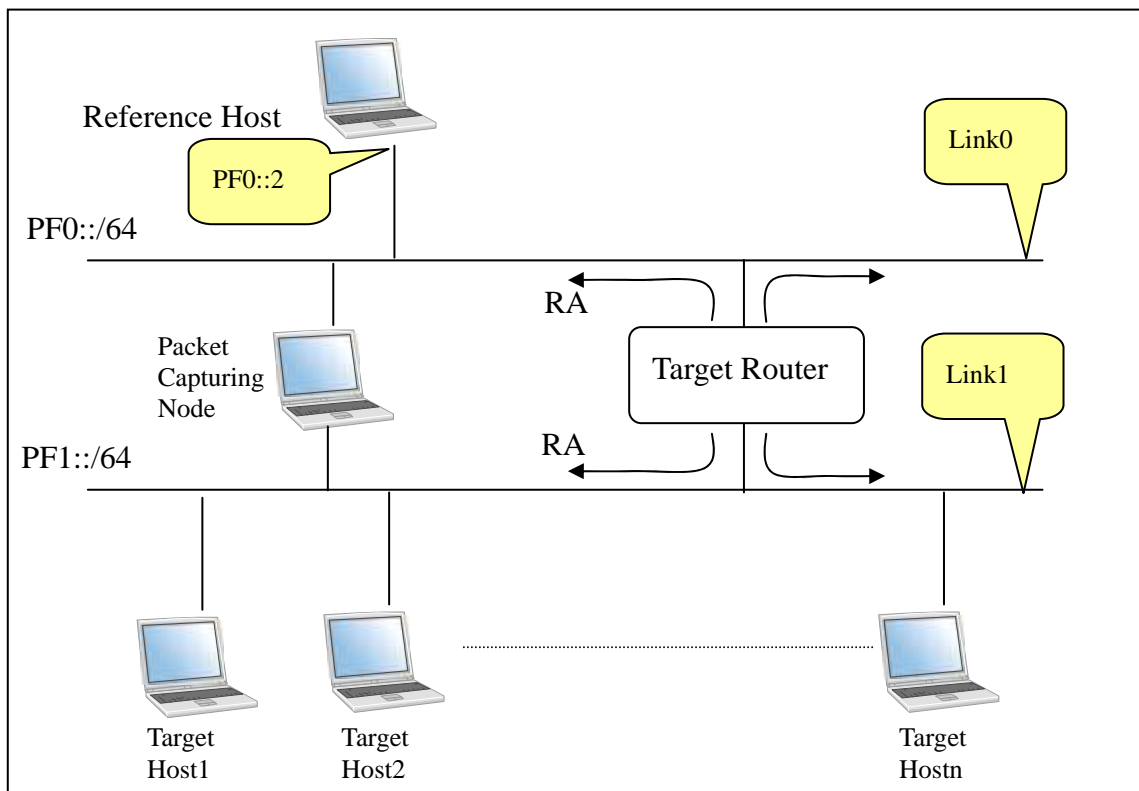

Fig. 2 1.Topology for Host vs. Router

There are two ways to run this test.

- 1) Make some sets of testing Network represented in Fig.2.1 using different Target Router.

In this case Target Hosts move every network.

- 2) Make one set of testing Network and change the Target Router

In this case all Target Hosts stay in the same network and the Target Router would be swapped when all Hosts complete required operations.

Condition:

- ◆ Target Router sends RA w/ one global prefix option on Link0 and Link1.
- ◆ If a Host can't send ICMP Echo Request, the node can omit it. But every host has to respond ICMP Echo Reply to received ICMP Echo Request.
- ◆ If your device is a **Special Device**, and it can not configure the address automatically, you need to assign address on the attached interface manually.
- ◆ If your device is a **Special Device**, and it can not set the default router automatically, set the Target Router's address as default router manually.

Operation on Host:

Run **ping** on each Host listed as "Host" to Router listed as "Router".

Save ping command log on each Host to individual file.

NOTE: To examine test result, command log file of every nodes are required.

Repeat same operation under each Router listed as "Router".

Router Host	Router1 (Link-local)	Router2 (Link-local)	Routern (Link-local)
Host1				
Host2				
:				
Hostn				

NOTE: You need to fill all of the cells your device is related. Even if your device is Router, you need to be sent ICMP Echo Request by opposite Hosts to confirm if your device can send ICMP Echo Reply correctly.

Operation on Router:

Run **ping** on each Router listed as "Router" to Host listed as "Host".

Save ping command log on each Router to individual file.

NOTE: To examine test result, command log file of every nodes are required.

Repeat same operation under each Router listed as "Router".

Host Router	Host1 (Link-local)	Host2 (Link-local)	Hostn (Link-local)
Router1				
Router2				
:				
Routern				

NOTE: You need to fill all of the cells your device is related. Even if your device is Host, you need to be sent ICMP Echo Request by opposite Router to confirm if your device can send ICMP Echo Reply correctly.

Operation on Packet Capturing Node:

Capture all the packets of Lik0 and Link1 during the test, and save to a file with tcpdump(pcap) format.

Repeat same operation for each Router listed as "Router".

2.2. Ping between Host and Router – Global Address

Ping from **Target Hosts** to **Target Routers** using **Global Address**.

Evaluation Point:

- ◆ ICMP Echo Request/Reply using Global address
- ◆ Global Address Generation (Using Received RA)
- ◆ Global Address Resolution (Both side)

Topology:

See topology described in Section 2.1.

Condition:

- ◆ Target Router sends RA w/ one global prefix option on Link0 and Link1.
- ◆ If a Host can't send ICMP Echo Request, the node can omit it. But every host has to respond ICMP Echo Reply to received ICMP Echo Request.
- ◆ If your device is a **Special Device**, and it can not configure the address automatically, you need to assign address on the attached interface manually.
- ◆ If your device is a **Special Device**, and it can not set the default router automatically, set the Target Router's address as default router manually

Operation on Host:

Run **ping** on each Host listed as "Host" to Router listed as "Router".

Save ping command log on each Host to individual file.

NOTE: To examine test result, command log file of every nodes are required.

Repeat same operation under each Router listed as "Router".

Router Host	Router1 (Global)	Router2 (Global)	Routern (Global)
Host1				
Host2				
:				
Hostn				

NOTE: You need to fill all of the cells your device is related. Even if your device is Router, you need to be sent ICMP Echo Request by opposite Hosts to confirm if your device can send ICMP Echo Reply correctly.

Operation on Router:

Run **ping** on each Router listed as "Router" to Host listed as "Host".

Save ping command log on each Router to individual file.

NOTE: To examine test result, command log file of every nodes are required.

Repeat same operation against each Host listed as "Host".

Host Router	Host1 (Global)	Host2 (Global)	Hostn (Global)
Router1				
Router2				
:				
Routern				

NOTE: You need to fill all of the cells your device is related. Even if your device is Host, you need to be sent ICMP Echo Request by opposite Router to confirm if your device can send ICMP Echo Reply correctly.

Operation on Packet Capturing Node:

Capture all the packets of Lik0 and Link1 during the test, and save to a file with tcpdump(pcap) format.

Repeat same operation for each Router listed as "Router".

2.3. Ping to Offlink Host

Ping from **Target Hosts** to **Reference Hosts** using **Global Address**.

Evaluation Point:

- ◆ Global Address Generation (Using Received RA)
- ◆ Default Router Selection (Using Received RA)
- ◆ Router's Link-local Address Resolution (Host side)
- ◆ Host's Global Address Resolution (Router side)

Topology:

See topology described in Section 2.1.

Condition:

- ◆ Target Router sends RA w/ one global prefix option on Link0 and Link1.
- ◆ If the target Host can not send ICMP Echo Request, sending ICMP Echo Reply to Reference Host satisfies the criteria, see "Operation on Host".
- ◆ If your device is a **Special Device**, and it can not configure the address automatically, you need to assign address on the attached interface manually.
- ◆ If your device is a **Special Device**, and it can not set the default router automatically, set the Target Router's address as default router manually.

Operation on Host:

Run **ping** on each Host listed as "Host" to Reference Host.

NOTE: If the target device can not send ICMP Echo Request, send ICMP Echo Request from Reference Host. And save the command log.

Save ping command log on each Host to individual file.

NOTE: To examine test result, command log file of every nodes are required.

Repeat same operation under each Router listed as "Router".

Router Host	Router1	Router2	Routern
Host1				
Host2				
:				
Hostn				

NOTE: You need to fill all of the cells your device is related. Even if your device is Router, you need to be sent ICMP Echo Request by opposite Hosts to confirm if your device can send ICMP Echo Reply correctly.

Operation on Packet Capturing Node:

Capture all the packets of Lik0 and Link1 during the test, and save to a file with tcpdump(pcap) format.

Repeat same operation for each Router listed as "Router".

3. Router vs. Router

The test scenarios described in this section are focusing on the interoperability between Routers, except Routing protocol.

3.1. Ping to Onlink Router with Link-local Address

Ping from **Target Routers** to **Other Target Routers** using **Link-local Address**.

Evaluation Point:

- ◆ Link-local Address resolution
- ◆ ICMP Echo Request/Reply using Link-local address

Topology:

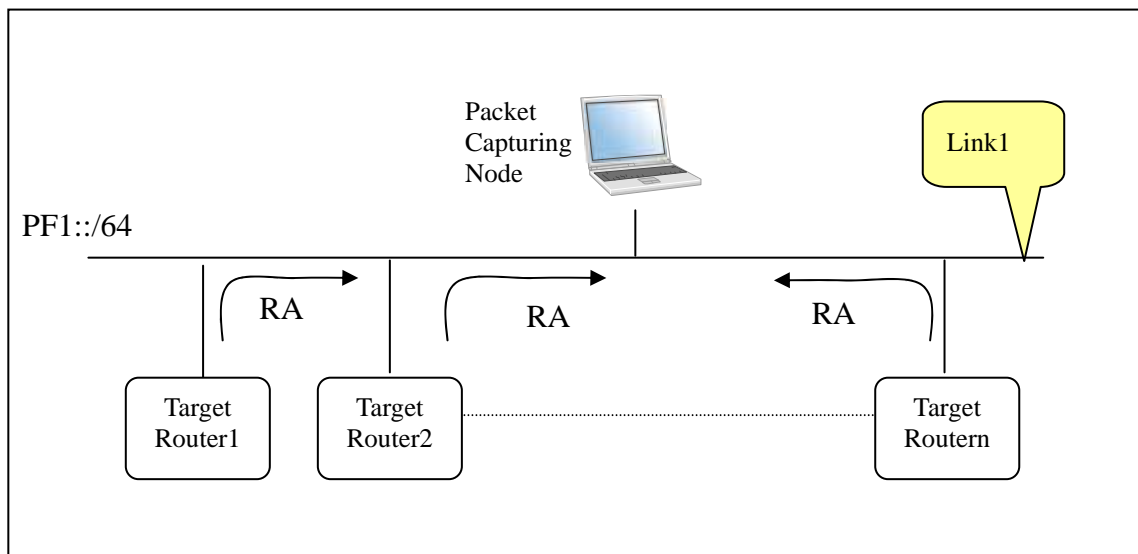

Fig. 3.1. Topology for Router vs. Router

Condition:

- ◆ Each Router sends RA on Link1.

Each Target Router attached to Link1 and performs following scenarios.

Operation on Router:

Run **ping** on Router listed as "From" to each Router listed as "To".

NOTE: You need to run ping command on your device as well as on other devices to your device.

Save ping command log on each Router to individual file.

NOTE: To examine test result, command log file of every nodes are required.

From \ To	Router1 (Link-local)	Router2 (Link-local)	Routern (Link-local)
Router1				
Router2				
:				
Routern				

NOTE: You need to fill all of the cells your device is related.

E.g.,) If your device is Router1, you need to fill both of Router1 Line and Router1 Column.

Operation on Packet Capturing Node:

Capture all the packets of Link1 during the test, and save to a file with tcpdump(pcap) format.

3.2. Ping to Onlink Router with Global Address

Ping from **Target Routers** to **Other Target Routers** using **Global Address**.

Condition: Each Router sends RA.

Evaluation Point:

- ◆ Global Address resolution
- ◆ ICMP Echo Request/Reply using Global address

Topology:

See topology described in Fig. 3.1.

Operation on Router:

Run **ping** on each Router listed as "From" to Router listed as "To".

NOTE: You need to run ping command on your device as well as on other devices to your device.

Save ping command log on each Router to individual file.

NOTE: To examine test result, command log file of every nodes are required.

From \ To	Router1 (Global)	Router2 (Global)	Routern (Global)
Router1				
Router2				
:				
Routern				

NOTE: You need to fill all of the cells your device is related.

E.g.,) If your device is Router1, you need to fill both of Router1 Line and Router1 Column.

Operation on Packet Capturing Node:

Capture all the packets of and Link1 during the test, and save to a file with tcpdump(pcap) format.

4. Change Log

1.3.3 from 1.3.2 Feb. 05th 2007

Remove "Configuration and information of each nodes" from Required data

"Configuration and information of each nodes" should be merged to "Topology map" as like as Phase-2

1.3.2 from 1.3.1 Jan. 30th 2006

Remove multibyte character

1.3.1 from 1.3 Dec. 9th 2005

Simplification of section 0.2 – Data file name syntax

1.3 from 1.2.4 Apr. 2nd 2004

Add description for Special Device.

Move the table to appropriate position.

Change the title of section 2.1 and 2.2.

1.2.4 from 1.2.3 Dec. 1st 2003

Specify tcpdump file format.

Change tcpdump command example.

Make command log file names for test 2.1-2.3) more specific.

1.2.3 from 1.2.2 Nov. 12th 2003

Add topology map as one of required documents for logo applications.

1.2.2 from 1.2.1 Nov. 4th 2003

In offlink communication test, sending ICMP Echo Reply is allowed if the target device can not send ICMP Echo Request.

Add explanation of application that sends ICMP Echo Request.

1.2.1 from 1.2 Oct. 31st 2003

Change the Title

Typographical errors

1.2 from 1.1 Oct. 28th 2003

Add "Required Data for IPv6 Ready Logo Phase-1 application" chapter

Remove test scenarios for ICMP Error message - Destination Unreachable

Remove test scenarios for ICMP Error message - Redirect

Remove test scenarios for ICMP Error message – Time exceed

Remove test scenarios, which use ping to multicast address.

1.1 from 1.0 Sep. 23rd 2003

Remove test scenarios, which evaluate packet fragmentation and reassembling.